

Service Manual

Turntable System

SL-1200MK2

[M], [MC],

[E], [EK], [XL], [EG], [EB], [EH],

[EF], [Ei], [XA], [PA], [PE], [PC]

SL-1210MK2

[E], [EG], [EH]

Supplement



*SL-1200MK2 is the model for silver type.

*SL-1210MK2 is the model for black type of SL-1200MK2.

Areas

- * [M] is available in the U.S.A.
- * [MC] is available in Canada.
- * [E] is available in Switzerland and Scandinavia.
- * [EK] is available in United Kingdom.
- * [XL] is available in Australia.
- * [EG] is available in F.R. Germany.
- * [EB] is available in Belgium.
- * [EH] is available in Holland.
- * [EF] is available in France.
- * [Ei] is available in Italy.
- * [XA] is available in Southeast Asia, Oceania, Africa, Middle Near East and Central South America.
- * [PA] is available in far East PX.
- * [PE] is available in European Military.
- * [PC] is available in European Audio Club.

Please use this manual together with the service manual for Model No. SL-1200MK2/1210MK2.

English

Specifications

Specifications are subject to change without notice for further improvement.
Weight and dimensions shown are approximate.

General

Power supply:	120V, AC 60 Hz (For [M], [MC] areas) ~ 110-120/220-240V, 50 or 60 Hz (For other areas)
Power consumption:	14 W (For [M], [MC] areas) 13.5 W (For other areas)
Dimensions: (W x H x D)	45.3 x 16.2 x 36 cm (17.27/32" x 6.19/64" x 14.11/64")
Weight:	12.5 kg (27.6 lb)

Turntable section

Type:	Quartz direct drive Manual turntable
Drive method:	Direct drive
Motor:	Brushless DC motor

Turntable platter:	Aluminum diecast Diameter 33.2 cm (13-5/64") Weight 2 kg (4.4 lb)
Turntable speeds:	33-1/3 rpm and 45 rpm
Starting torque:	1.5 kg · cm (1.3 lb · in)
Build-up characteristics:	0.7 s. from standstill to 33-1/3 rpm
Braking system:	Electronic brake
Wow and flutter:	0.01% WRMS* 0.025% WRMS (JIS C5521) ± 0.035% peak (IEC 98A Weighted)

* This rating refers to turntable assembly alone, excluding effects of record, cartridge or tonearm, but including platter.
Measured by obtaining signal from built-in frequency generator of motor assembly.

Rumble:	-56 dB (IEC 98A Unweighted) -78 dB (IEC 98A Weighted)
---------	--

Matsushita Engineering and Service Company
50 Meadowland Parkway,
Secaucus, New Jersey 07094

Panasonic Hawaii Inc.
91-238 Kauhū St. Ewa Beach
P.O. Box 774
Honolulu, Hawaii 96808-0774

Panasonic Sales Company,
Division of Matsushita Electric
of Puerto Rico, Inc.
Ave. 65 De Infanteria, KM 9.7
Victoria Industrial Park
Carolina, Puerto Rico 00630

Matsushita Electric
of Canada Limited
5770 Ambler Drive, Mississauga,
Ontario, L4W 2T3

Technics

Panasonic Tokyo
Matsushita Electric Industrial Co., Ltd.
1-2, 1-chome, Shibakoen, Minato-ku, Tokyo 105 Japan

Matsushita Electric Trading Co., Ltd.
P.O. Box 288, Central Osaka Japan

Tonearm section

Type:	Universal
Effective length:	230 mm (9-1/16")
Arm height adjustment range:	0 - 6 mm
Overhang:	15 mm (19/32")
Effective mass:	12 g (without cartridge)
Offset angle:	22°
Friction:	Less than 7 mg (lateral, vertical)
Tracking error angle:	Within 2°32' (at the outer groove of 30 cm (12") record Within 0°32' (at the inner groove of 30 cm (12") record)

Stylus pressure adjustment range:	0 - 2.5 g
Applicable cartridge weight range:	6 - 10 g
(with auxiliary weight):	13.5 - 17.5 g (including headshell) 9.5 - 13 g
(with shell weight):	17 - 20.5 g (including headshell) 3.5 - 6.5 g
Headshell weight:	11 - 14 g (including headshell) 7.5 g

Notes

- ★ To improve the performance of SL-1200MK2/1210MK2, the bottom structure and circuit are changed in the course of production.
- ★ After the change, SL1200MK2-A/1210MK2-A is indicated in the name plate as the model of the set. It is discriminated from before-change set by -A. Also, check that the present change is of the sets after the change mark **D** shown in the serial No. sheet attached to the bottom and carton box.
- ★ This supplement service manual contains the bottom plate disassembly procedure, change part No., circuit diagram, P.C.B. and block diagrams. The other contents are the same as for the service manual of SL-1200MK2/1210MK2 already issued.
- ★ Sets with cartridge (EPC-207C) are included in those for same areas.
- ★ Since the power transformer fitting method is different for sets with serial number sheet change mark **E**, refer to the development plan on page 8.

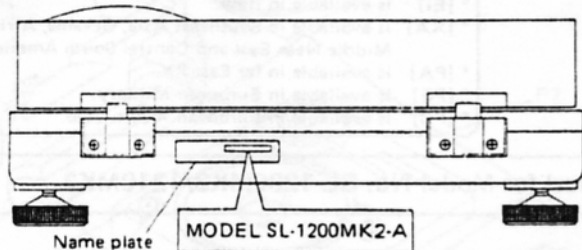

Serial No. sheet

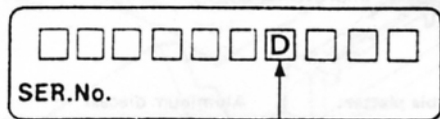

Change mark

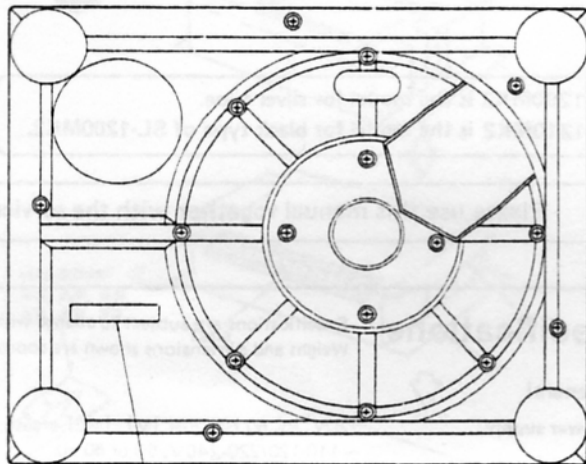

Serial No. sheet

Deutsch

TECHNISCHE DATEN

Änderungen der technischen Daten vorbehalten.
Die angegebenen Gewichts- und Abmessungsdaten sind ungefähre Werte.

Allgemeine Daten

Stromversorgung:	~ 110-120/220-240 V, 50/60 Hz Wechselstrom
Leistungsaufnahme:	13,5 W
Abmessungen: (B x H x T):	45,3 x 16,2 x 36 cm
Gewicht:	12,5 kg

Plattenspieler

Typ:	Manueller Quarz-Direktantrieb-Plattenspieler
Antrieb:	Direktantrieb
Motor:	Kollektorloser Gleichstrommotor
Plattenteller:	Aluminium-Spritzguß Durchmesser 33,2 cm Gewicht 2 kg

Plattenteller-Drehzahlen:	33-1/3 und 45 U/min
Anlautdrehmoment:	1,5 kg · cm
Drehzahl-Hochlaufzeit:	0,7 s. vom Stillstand auf 33-1/3 U/min
Bremssystem:	Elektronische Bremse
Gleichlaufschwankungen:	0,01% WRMS* 0,025% WRMS (JIS C5521) ± 0,035% Spitze (IEC 98A bewertet)

* Diese Nennleistung bezieht sich auf das Laufwerk-Bauteil allein, ausschließlich Einflüsse von Schallplatte, Tonabnehmer oder Tonarm, aber einschließlich Plattenteller.
Gemessen anhand von Signalen vom eingebauten Frequenzgenerator des Motorbauteils.

Rumpel-Geräuschspannungsabstand:	-56 dB (IEC 98A unbewertet) -78 dB (IEC 98A bewertet)
----------------------------------	--

■ Tonarm

Typ:	Universal-Tonarm	Auflagekraft-	
Effektive Länge:	230 mm	Einstellbereich:	0 – 2,5 g
Tonarmhöhe-		Zulässiger Tonabnehmer-	
Einstellbereich:	0 – 6 mm	Gewichtsbereich:	6 – 10 g
Überhang:	15 mm		13,5 – 17 g (einschließlich Tonarmkopf)
Effektive Masse:	12 g (ohne Tonabnehmer)	(mit Zusatz-	
Spurfehlwinkel:	2°32' bei der Einlaufrille einer 30 cm-Platte	Gegengewicht):	9,5 – 13 g
	0°32' bei der Auslaufrille einer 30 cm-Platte	Gewichtsbereich:	17 – 20,5 g (einschließlich Tonarmkopf)
		(mit Zusatzgewicht)	11 – 14 g (einschließlich Tonarmkopf)
Kröpfungswinkel:	22°	Tonarmkopf-Gewicht:	7,5 g
Lagerreibung:	Weniger als 7 mg (horizontal, vertikal)		

Français

CARACTERISTIQUES

Les spécifications sont susceptibles d'être modifiées sans préavis.
Le poids et les dimensions donnés sont approximatifs.

■ Généralités

Alimentation:	Alternatif 110-120/220-240 V, 50 ou 60 Hz
Consommation:	13,5 W
Dimensions: (L x H x P)	45,3 x 16,2 x 36 cm
Poids:	12,5 kg

■ Platine de lecture

Type:	Entaînement direct à quartz Platine manuelle
Système d'entraînement:	Entraînement direct
Moteur:	Moteur C.C. sans balai
Plateau de lecture:	Aluminium moulé sous pression Diamètre 33,2 cm Poids 2 kg
Vitesses de rotation:	33-1/3 et 45t/p.m.
Couple de démarrage:	1,5 kg · cm
Caractéristiques	
d'augmentation:	0,7 s. (rotation de 90°) à 33-1/3 t/p.m.
Système de freinage:	Frein électronique
Pleurage et scintillement:	0,01% de valeur efficace* 0,025% de valeur efficace (JIS C5521) ± 0,35% de crête (IEC 98A Pondéré)

*Ce régime nominal se rapporte à l'ensemble du tournedisque seul, excluant les effets du disque, de la cellule pick-up ou de bras de lecture, mais comprenant le plateau.

Mesuré par l'obtention d'un signal provenant du générateur de fréquences incorporé de l'ensemble du moteur.

Ronflement:	-56 dB (IEC 98A Non pondéré) -78 dB (IEC 98A Pondéré)
--------------------	--

■ Bras de lecture

Type:	Bras de lecture universel
Longueur effective:	230 mm
Portée du réglage de la	
hauteur de bras:	0 – 6 mm
Porte-à-faux:	15 mm
Masse réelle:	12 g (sans la cellule pick-up)
Angle d'erreur de piste:	En deçà de 2°32' au sillon extérieur d'un disque de 30 cm En deçà de 0°32' au sillon intérieur d'un disque de 30 cm
	22°
Angle de décalage:	
Frottement:	Moins de 7 mg (latéral et vertical)
Plage de réglage de la	
pression d'appui:	0 – 2,5 g
Gamme du poids de la	
cellule pick-up	
utilisable:	6 – 10 g 13,5 – 17,5 g (y compris la coque porte-cellule)
(avec contrepoids	
auxiliaire):	9,5 – 13 g 17 – 20,5 g (y compris la coque porte-cellule)
(avec contrepoids de	
la cellule):	3,5 – 6,5 g 11 – 14 g (y compris la coque porte-cellule)
Poids de la cellule:	7,5 g

ESPECIFICACIONES

Las especificaciones quedan sujetas a cambios sin aviso previo.
El peso y las dimensiones indicados son aproximados.

En general

Alimentación de corriente:	~ 110-120/220-240 V, 50 ó 60 Hz
Consumo de corriente:	13,5 W
Dimensiones:	45,3 x 16,2 x 36 cm
(Ancho x Alto x Prof.)	
Peso:	12,5 kg

Sección del plato giratorio

Tipo:	Plato giratorio manual de accionamiento directo por cuarzo
Método de accionamiento:	Accionamiento directo
Motor:	Motor de corriente continua sin escobillas
Platillo del plato giratorio:	Aluminio fundido Diámetro 33,2 cm Peso 2 kg.
Velocidades del plato giratorio:	33-1/3 y 45 rpm
Par motor de arranque:	1,5 kg · cm
Características de establecimiento:	0,7 s. (a partir de reposo) hasta 33-1/3 rpm
Sistema de frenado:	Freno electrónico
Ululaciones y trémolo:	0,01% WRMS* 0,025% WRMS (JIS C5521) ± 0,035% cresta (IEC 98A Ponderado)

*Estas características se refieren únicamente al conjunto del plato giratorio, con exclusión de los efectos provenientes del disco, cartucho o del brazo sonoro, incluyendo, empero, el platillo. La medida fue tomada por medio de la señal obtenida del generador de frecuencia incorporado del conjunto del motor.

Ruido de rodadura:	-56 dB (IEC 98A No Ponderado) -78 dB (IEC 98A Ponderado)
---------------------------	---

Sección del brazo sonoro

Tipo:	Brazo sonoro universal
Longitud efectiva:	230 mm
Radio de ajuste de altura del brazo:	0 - 6 mm
Parte saliente:	15 mm
Masa efectiva:	12 g. (sin cartucho)
Angulo de descentramiento:	22°
Fricción:	Menos de 7 mg. (en sentido lateral y vertical)
Angulo de error de seguimiento:	Inferior a 2°32' en el surco exterior de un disco de 30 cm Inferior a 0°32' en el surco interior de un disco de 30 cm
Radio de ajuste de la presión de la aguja:	0 a 2,5 g.
Radio de peso de cartucho utilizable:	6 a 10 g. 13,5 a 17,5 g. (incluyendo la cápsula de la cabeza)
(con contrapeso de balance de reserva):	9,5 a 13 g. 17 a 20,5 g. (incluyendo la cápsula de la cabeza)
(con contrapeso de la cápsula):	3,5 a 6,5 g. 11 a 14 g. (incluyendo la cápsula de la cabeza)
Peso de la cápsula de la cabeza:	7,5 g

CHANGES

DISASSEMBLY INSTRUCTIONS

● How to remove the bottom cover and bottom base.

1. Remove the turntable mat and turntable.
2. Turn over the body on a soft cloth taking care not to damage the dust cover.
3. Remove the insulators and the 21 setscrews (Fig. 1 : ①, ②, ③) of the bottom cover.
4. Remove the 6 setscrews (Fig. 2 : ④) of the bottom base.

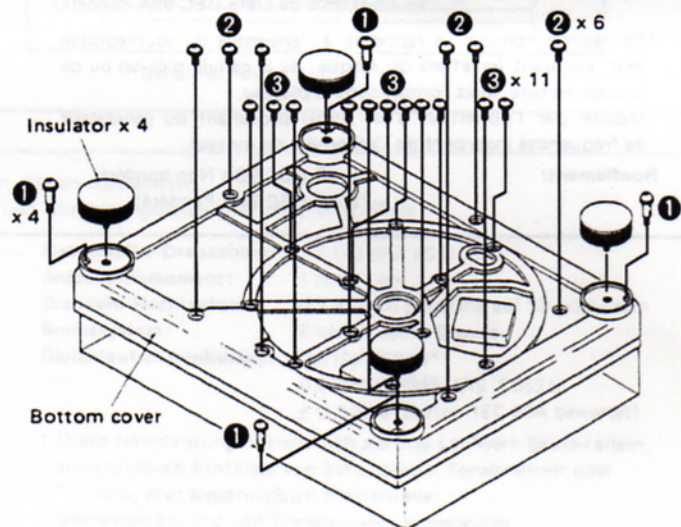

Fig. 1

● How to remove the hinge case

1. Remove the bottom cover. (Refer to "How to remove the bottom cover".)
2. Remove the 4 setscrews (Fig. 2 : ⑤) of the hinge case bracket.
3. Remove the 4 setscrews (Fig. 2 : ⑥) of the hinge case.

Note: The other disassembly procedure are the same as for before-change sets.

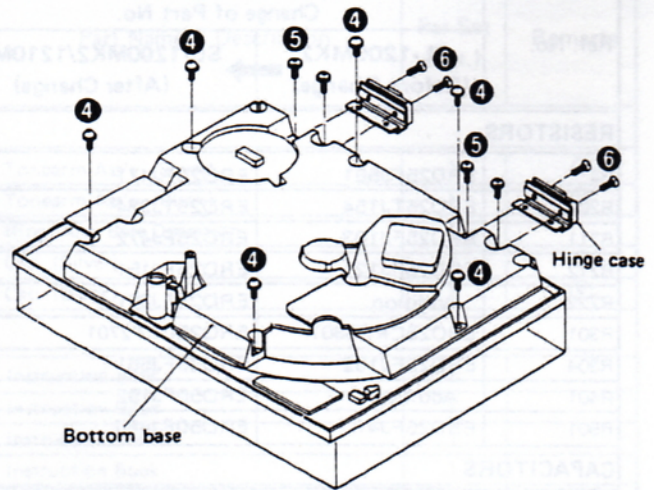

Fig. 2

● REPLACEMENT PARTS LIST

Notes:

1. This parts list mentions only the difference between before and after change of SL-1200MK2/1210MK2.
2. ⊗ -marked parts are used only for SL-1210MK2 (black type). And ○ -marked parts are used for SL1200MK2 (silver type).
3. Parts other than ⊗ - and ○ -marked are used for both SL-1210MK2 and SL-1200MK2.
4. The "Ⓢ" mark is service standard parts and may differ from production parts.

Areas

- [M] is available in the U.S.A.
- [MC] is available in Canada.
- [E] is available in Switzerland and Scandinavia.
- [EK] is available in United Kingdom.
- [XL] is available in Australia.
- [EG] is available in F.R. Germany.
- [EB] is available in Belgium.
- [EH] is available in Holland.
- [EF] is available in France.
- [Ei] is available in Italy.
- [XA] is available in Southeast Asia, Oceania, Africa, Middle Near East and Central South America.
- [PA] is available in far East PX.
- [PE] is available in European Military.
- [PC] is available in European Audio Club.

Ref. No.	Change of, Part No.		Part Name & Description	Per Set (Pcs.)	Remarks
	SL-1200MK2 (Before Change)	SL-1200MK2/1210MK2 (After Change)			
INTEGRATED CIRCUIT					
IC302	SVITC4011BP	MN4011B	NAND Gate	1	
TRANSISTOR					
Q1	2SD389A-Q	2SD1265	Regulator	1	
DIODES					
D1	SVDS1RBA40	SVDS1RBA20Z	Rectifier	1	△
D201, 202	SVDSR-105C	SV DPR3902S-9	Speed Indicator	2	
D203 ~ 206	SVDEBR5505S	SVDSLH54VT3	Strobe	4	
D401	SVDGL-9PG2	SVDGL-9NG2	Pitch Indicator	1	
CRYSTAL					
X201	SVQU306115	SVQMS4193	4.193 MHz, Oscillator	1	
VARIABLE RESISTORS					
VR301	EVMH2GA00B53	EVMH1GA00B23	Pitch Control Adjustment, 2kΩ (B)	1	
VR303	EVB05C19ABE	SFDZ122N11	Pitch Control	1	
SWITCHES					
S203	SFDSS5GL13C	SFDSS01GL13	Start/Stop	1	
S601	SFDSS5GL13S	SFDSS5GL13P	Power	1	△
TRANSFORMER					
T1	SLT60EU7B	SLT66DTL3A [M]	Power Source	1	△
T1	SLT60E31C	SLT66DT14C [MC]	Power Source	1	△
T1	SLTF5900	SLT66DTE13A [Other areas]	Power Source	1	△

SL-1200MK2 / 1210MK2

Ref. No.	Change of Part No.		Part Name & Description	Per Set (Pcs.)	Remarks
	SL-1200MK2 (Before Change)	SL-1200MK2/1210MK2 (After Change)			
RESISTORS					
R4	ERD25FJ561	ERD25FJ471	Carbon, 1/4W, 470Ω	1	Ⓢ
R209	ERD25TJ154	ERD25TJ334	Carbon, 1/4W, 330kΩ	1	Ⓢ
R211	ERD25FJ103	ERD25FJ472	Carbon, 1/4W, 4.7kΩ	1	Ⓢ
R212	ERD25FJ121	ERD25FJ151	Carbon, 1/4W, 150Ω	1	Ⓢ
R222	Addition	ERD25FJ391	Carbon, 1/4W, 390Ω	1	Ⓢ
R301	ERO25CKF3301	ERO25CKF2701	Metal Film, 1/4W, 2.7kΩ	1	Ⓢ
R304	ERD25FJ152	ERD25FJ561	Carbon, 1/4W, 560Ω	1	Ⓢ
R401	Addition	ERD50FJ152	Carbon, 1/2W, 1.5kΩ	1	Ⓢ
R601	ERD25FJ4R7	ERD50FJ4R7	Carbon, 1/2W, 4.7Ω	1	Δ Ⓢ
CAPACITORS					
C5, 6	Addition	ECQM1223KZ	Polyester, 125V, 0.022μF	1	Δ
C104 ~ 107	ECQM1H104KZ	ECQM1H104JZ	Polyester, 50V, 0.1μF	4	Ⓢ
C109, 110	ECQM1H104KZ	ECQM1H104JZ	Polyester, 50V, 0.1μF	2	Ⓢ
C111	ECQM1H562KZ	ECQM1H562JZ	Polyester, 50V, 0.0056μF	1	Ⓢ
C204	ECQM1H473KZ	ECQM1H473JZ	Polyester, 50V, 0.047μF	1	Ⓢ
C210	ECQM1H224KZ	ECQM1H224JZ	Polyester, 50V, 0.22μF	1	Ⓢ
C211	ECQM1H473KZ	ECQM1H473JZ	Polyester, 50V, 0.047μF	1	Ⓢ
C217 ~ 219	Addition	ECKD1H104ZF	Ceramic, 50V, 0.1μF	1	Ⓢ
C301	ECQK1123FZ	ECQK1333GZ	Polyester, 125V, 0.033μF	1	
C302	ECQK1123FZ	ECQK1682GZ	Polyester, 125V, 0.0068μF	1	
C305	ECQM1H122KZ	ECQM1H122JZ	Polyester, 50V, 0.0012μF	1	Ⓢ
CABINET and CHASSIS PARTS					
9	SFUP122-12	Deletion	0	
10	SFAC122-01	SFAC122-01	Cabinet (Silver)	1	Ⓢ
		SFAC124S01	Cabinet (Black)	1	Ⓢ
25	SFXB122-02	SFXB122-06	Boss, Drive	1	
33	SFQA001-02	SFQA122-03	Spring	1	
36	SFUP025-01	SFUP122-16 [M, MC, PA, PE, PC]	Bracket, AC Cord	1	
	SFUP025X01	SFUP122X01 [Other areas]	Bracket, AC cord	1	
38	SFUP132-03	SFGC122-03	Cushion	2	
40	SFUP122-10	Deletion	0	
42	SFKK122-03	SFKK122-03	Plate (Silver)	1	
		SFKK124S01	Plate (Black)	1	
48	SFAU122-01	SFAU122-02	Bottom Base	1	
48-1	Addition	SFAU122-03	Bottom Cover	1	
49	SFUP122-05	SFUP122-23	Supporter (A), Hinge	2	
50	SFUP122-04	SFUP122-24	Supporter (B), Hinge	2	
51	SFUM170-07	SFUJMM02N04	Case, Hinge	2	
55	SFNN122M01	SFNN122M10 [M]	Name Plate	1	○
	SFNN122C01	SFNN122C10 [MC]	Name Plate	1	○
	SFNN122S01	SFNN122S10 [E]	Name Plate	1	○
	SFNN122L01	SFNN122G10 [EK, XL]	Name Plate	1	○
	SFNN122X01	SFNN122X10 [XA]	Name Plate	1	○
	Addition	SFNN122P10 [PA, PE]	Name Plate	1	○
	Addition	SFNN122P11 [PC]	Name Plate	1	○
	SFNN122N01	SFNN122N10 [Other areas]	Name Plate	1	○
	Addition	SFNN124S10 [E]	Name Plate	1	Ⓢ
Addition	SFNN124Q10 [EG, EH]	Name Plate	1	Ⓢ	
56	SFX0122-01	Deletion	0	
57	SFX0122-02	Deletion	0	
58	SFAT122-01A	SFATM02N01A	Hinge	1	

Ref. No.	Change of Part No.		Part Name & Description	Per Set (Pcs.)	Remarks
	SL-1200MK2 (Before Change)	SL-1200MK2/1210MK2 (After Change)			
TONARM PARTS					
62	SFPAM18201K	SFPAM18201K	Tonearm Ass'y (Silver)	1	○
		SFPAM18202K	Tonearm Ass'y (Black)	1	Ⓚ
79	SFPKB17201S	SFPKB17204E	Ring, Arm Base Operation	1	
82	SFGK132-01	SFGK132-01	Cap (Silver)	1	○
		SFGK133S01	Cap (Black)	1	Ⓚ
ACCESSORIES					
A1	SFNU122M01	SFNU122M06 [M]	Instruction Book	1	
	SFNU122C01	SFNU122C06	Instruction Book	1	
	SFNU122S01	SFNU122S01 [E]	Instruction Book	1	
	SFNU122G01	SFNU122G01 [EK]	Instruction Book	1	
	Addition	SFNU122P01 [PA, PE, PC]	Instruction Book	1	
	SFNU122X01	SFNU122X01 [Other areas]	Instruction Book	1	
A2	SFWE010	SFWE122-01	45 Adaptor	1	
PACKING PARTS					
P1	SFHP122C01	SFHP122C02 [MC, EF]	Carton Box (Silver)	1	○
	SFHP122M01	SFHP122M02 [Other areas]	Carton Box (Silver)	1	○
		SFHP124S02	Carbon Box (Black)	1	Ⓚ
P9	Addition	SPB1083	Polyethylene Bag, Accessories	2	
P10	Addition	SPJ15	Polyethylene Bag, Shell Weight	1	
P11	Addition	SFHZD03M01	Polyethylene Bag, Dust Cover	3	
P12	Addition	SFHZ122-01	Polyethylene Bag, 45 Adaptor	1	
P13	Addition	SPP189	Polyethylene Bag, Cords	2	

• ADJUSTMENT POINTS

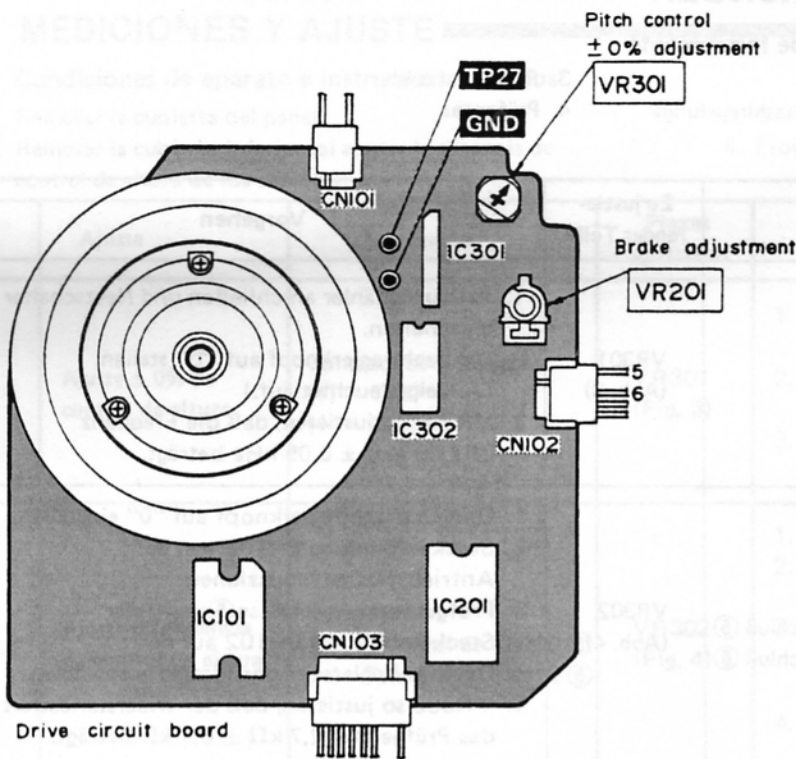

Fig. 3 (Abb. 3)

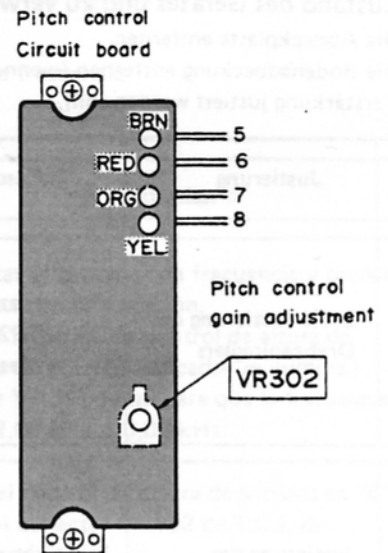

Fig. 4 (Abb. 4)

MEASUREMENTS AND ADJUSTMENTS English

• Conditions of set, and instruments used

- 1. Remove the panel cover.
- 2. Remove the bottom cover (when adjusting the pitch control gain).
- 3. Frequency counter
- 4. Tester

	Adjustment	Connection	Parts adjusted	Procedure
1	Pitch control $\pm 0\%$ adjustment	Frequency counter (+) – TP27 (–) – Earth point	VR301 (Fig. 3)	<ol style="list-style-type: none"> 1. Connect the frequency counter and turn the power supply ON. 2. Set the pitch control knob to "0". (Indicator lights up.) 3. Adjust VR301 so that the frequency is 262.08 kHz \pm 0.05 kHz.
2	Pitch control gain adjustment	Tester (+) – CN102 terminal ⑤ (–) – CN102 terminal ⑥	VR302 (Fig. 4)	<ol style="list-style-type: none"> 1. Set the pitch control knob to "0". 2. Pull out the connector CN102 of drive P.C.B. 3. Connect the tester to terminals ⑤ and ⑥ of connector CN102 on the pitch control P.C.B. side. 4. Adjust VR302 so that the resistance value of the tester is 2.7 kΩ \pm 0.1 kΩ.
3	Brake adjustment	_____	VR201 (Fig. 3)	<ol style="list-style-type: none"> 1. Adjust VR201 so that the rotation at 33 r.p.m. stops within the angle of 90° ~ 120° after depressing the stop button.

MESSUNGEN UND JUSTIERUNGEN Deutsch

• Zustand des Gerätes und zu verwendende Instrumente

- 1. Die Abdeckplatte entfernen.
- 2. Die Bodenabdeckung entfernen (wenn die Drehzahlregelungs-Verstärkung justiert werden soll).
- 3. Frequenzzähler
- 4. Prüfgerät

	Justierung	Anschlüsse	Zu justie- render Teile	Vorgehen
1	$\pm 0\%$ -Justierung des Drehzahlreglers	Frequenzzähler (+) – TP27 (–) – Massepunkt	VR301 (Abb. 3)	<ol style="list-style-type: none"> 1. Frequenzzähler anschließen und Netzschalter einschalten. 2. Drehzahlreglerknopf auf "0" stellen. (Anzeige leuchtet auf.) 3. VR301 so justieren, daß die Frequenz 262,08 kHz \pm 0,05 kHz beträgt.
2	Justierung der Drehzahlregelungs-Verstärkung	Prüfgerät (+) – CN102 Anschluß ⑤ (–) – CN102 Anschluß ⑥	VR302 (Abb. 4)	<ol style="list-style-type: none"> 1. Den Drehzahlreglerknopf auf "0" einstellen. 2. Steckverbindung CN102 von der Antriebsplatine herausziehen. 3. Prüfgerät an Anschlüsse ⑤ und ⑥ der Steckverbindung CN102 auf der Drehzahlreglerseite der Platine anschließen. 4. VR302 so justieren, daß der Widerstandswert des Prüfgerätes 2,7 kΩ \pm 0,1 kΩ beträgt.
3	Bremsjustierung	_____	VR201 (Abb. 3)	<ol style="list-style-type: none"> 1. VR201 so justieren, daß die Rotation bei 33 UPM innerhalb 90° ~ 120° nach Drücken der Stop-Taste stoppt.

MESURAGES ET RÉGLAGES Français

• Conditions de l'appareil et appareils utilisés.

1. Retirer le panneau de protection.
2. Retirer le panneau de protection inférieur (lors de l'ajustement de l'amplification du réglage d'écart).
3. Compteur de fréquence
4. Appareil contrôleur

	Mise au point	Raccordement	Elements à régler	Marche à suivre
1	Ajustement de $\pm 0\%$ du réglage d'écart	Compteur de fréquence (+) – TP27 (-) – Point de contact à la terre	VR301 (Fig. 3)	<ol style="list-style-type: none"> 1. Raccorder le compteur de fréquence et mettre en marche l'alimentation. 2. Régler le bouton du réglage d'écart sur "0". (L'indicateur s'éclairera.) 3. Ajuster VR301 de telle sorte que la fréquence soit de $262,08 \text{ kHz} \pm 0,05 \text{ kHz}$.
2	Ajustement de l'amplification du réglage d'écart	Appareil contrôleur (+) – Borne CN102 ⑤ (-) – Borne CN102 ⑥	VR302 (Fig. 4)	<ol style="list-style-type: none"> 1. Régler le bouton de réglage d'écart sur "0". 2. Retirer le connecteur CN102 de la plaquette à circuits imprimés de commande. 3. Raccorder l'appareil contrôleur aux bornes ⑤ et ⑥ du connecteur CN102 sur le côté de la plaquette à circuits imprimés du réglage d'écart. 4. Ajuster VR302 de telle sorte que la valeur de résistance de l'appareil contrôleur soit de $2,7 \text{ k}\Omega \pm 0,1 \text{ k}\Omega$.
3	Ajustement du frein	_____	VR201 (Fig. 3)	<ol style="list-style-type: none"> 1. Régler VR201 de telle sorte que la rotation à 33 t/p.m. s'arrête en deçà d'un angle de $90^\circ \sim 120^\circ$ après avoir appuyé sur la touche d'arrêt.

MEDICIONES Y AJUSTE Español

• Condiciones de aparato e instrumentos usados

1. Remover la cubierta del panel.
2. Remover la cubierta inferior (al ajustar la ganancia de control de altura de los sonidos).
3. Contador de frecuencia
4. Probador

	Ajuste	Conexión	Piezas ajustadas	Procedimiento
1	Ajuste $\pm 0\%$ de control de altura	Contador de frecuencia (+) – TP27 (-) – Punto de tierra	VR301 (Fig. 3)	<ol style="list-style-type: none"> 1. Conectar el contador de frecuencia y prender la fuente de alimentación. 2. Ajustar la perilla de control de altura de sonidos a "0". (El indicador se ilumina.) 3. Ajustar VR301 de manera que la frecuencia sea $262,08 \text{ kHz} \pm 0,05 \text{ kHz}$.
2	Ajuste de ganancia de control de altura	Probador (+) – Terminal de CN102 ⑤ (-) – Terminal de CN102 ⑥	VR302 (Fig. 4)	<ol style="list-style-type: none"> 1. Poner el control de altura de sonidos en "0". 2. Sacar el conector CN102 de T.C.I. de accionamiento. 3. Conectar el probador a terminales ⑤ y ⑥ de conector CN102 del lado de T.C.I. de control de altura. 4. Ajustar VR302 de manera que el valor de resistencia del probador sea $2,7 \text{ k}\Omega \pm 0,1 \text{ k}\Omega$.
3	Ajuste de freno	_____	VR201 (Fig. 3)	<ol style="list-style-type: none"> 1. Ajustar VR201 de manera que la rotación a 33 r.p.m. se pare dentro del ángulo de $90^\circ \sim 120^\circ$ después oprimir el botón de parada.

RESISTORS AND CAPACITORS

- Notes:**
- Part numbers are indicated on most mechanical parts. Please use this part number for parts orders.
 - Important safety notice: Components identified by Δ mark have special characteristics important for safety. When replacing any of these components use only manufacturer's specified parts.
 - The "S" mark is service standard parts and may differ from production parts.
 - Bracketed indications in Ref. No. colum specify the area. Parts without these indications can be used for all area.
 - The unit of resistance is Ω (ohm).
K = 1000 Ω , M = 1000k Ω
 - The unit capacitance is μ F (microfarad).
P = 10⁻⁶ μ F

Areas

- [M] is available in the U.S.A.
- [MC] is available in Canada.
- [E] is available in Switzerland and Scandinavia.
- [EK] is available in United Kingdom.
- [XL] is available in Australia.
- [EG] is available in F.R. Germany.
- [EB] is available in Belgium.
- [EH] is available in Holland.
- [EF] is available in France.
- [Ei] is available in Italy.
- [XA] is available in Southeast Asia, Oceania, Africa, Middle Near East and Central South America.
- [PA] is available in far East PX.
- [PE] is available in European Military.
- [PC] is available in European Audio Club.

Numbering System of Resistor

Example

ERD	25	F	J	101
Type	Wattage	Shape	Tolerance	Value
ERX	2	AN	J	2R2
Type	Wattage	Shape	Tolerance	Value

Resistor type	Wattage	Tolerance
ERD: Carbon	25 : 1/4W	F : \pm 1%
ERG: Metal Oxide	50 : 1/2W	J : \pm 5%
ERO: Metal Film	1A : 1W	
ERX: Metal Film	2A : 2W	

Numbering System of Capacitor

Example

ECKD	1H	102	Z	F
Type	Voltage	Value	Tolerance	Peculiarity
ECEA	50	M	R47	R
Type	Voltage	Peculiarity use	Value	Special use

Capacitor Type	Voltage	Tolerance
ECEA : Electrolytic	OJ : 6.3V	J : \pm 5%
ECEB : Electrolytic	1C : 16V	K : \pm 5%
ECCD : Ceramic	1E : 25V	M : \pm 20%
ECQM : Polyester	1H : 50V	Z : +80%, -20%
ECQU : Polyester	1 : 100V	
ECQF : Polyester	1A : 125V	
ECNC : Polyester	4A : 400V	

Ref No	Part No	Value	Ref No	Part No	Value	Ref No	Part No	Value	Ref No	Part No	Value
RESISTORS			R210	⑤ ERD25TJ183	18K	CAPACITORS			C210	⑤ ECQM1H224JZ	0.22
R1	⑤ ERD25FJ562	5.6K	R211	⑤ ERD25FJ472	4.7K	C1	ECEB1HU471	470	C211	⑤ ECEM1H473JZ	0.047
R2	⑤ ERD25FJ682	6.8K	R212	⑤ ERD25FJ151	150	C2	ECEA1EU330	33	C212	ECEA1HU3R3	3.3
R3	⑤ ERD25FJ272	2.7K	R213	⑤ ERD25FJ122	1.2K	C3	ECEA1EU220	22	C213	⑤ ECCD1H471K	470P
R4,5	⑤ ERD25FJ471	470	R214	⑤ ERD25TJ223	22K	C5,6	ECQM1223KZ	0.022	C214	ECEA1CU101	100
R101	⑤ ERD25FJ103	10K	R215	⑤ ERD25FJ472	4.7K	C101,102	ECEA1EU330	33	C215	ECEA1HU010	1
R102	⑤ ERX1ANJ4R7	4.7	R216	⑤ ERD25TJ154	150K	C103	ECEA1EU330	33	C216	ECEA1CU470	47
R103	⑤ ERD25FJ472	4.7K	R217	⑤ ERD25TJ223	22K	C104,105	⑤ ECQM1H104JZ	0.1	C217,218	ECKD1H104ZF	0.1
R104	⑤ ERD25TJ473	47K	R218	⑤ ERD25FJ102	1K	C106,107	⑤ ECQM1H104JZ	0.1	C219	ECKD1H104ZF	0.1
R105	⑤ ERD25FJ103	10K	R219	⑤ ERD25FJ332	3.3K	C108	ECEA1EU101	100	C301	ECQK1333GZ	0.033
R106	⑤ ERD25FJ150	15	R220	⑤ ERD25FJ221	220	C109,110	⑤ ECQM1H104JZ	0.1	C302	ECQK1682GZ	0.0068
R107	⑤ ERX1ANJ1R5	1.5	R221	⑤ ERD25FJ471	470	C111	⑤ ECQM1H562JZ	0.0056	C303	ECEA1HU010	1
R108	⑤ ERD25FJ103	10K	R222	⑤ ERD25FJ391	390	C112	ECEA1HU4R7	4.7	C304	ECEA1CU100	10
R109,110	⑤ ERX1ANJ4R7	4.7	R301	⑤ ER025CKF2701	2.7K	C201	ECEA1CU330	33	C305	⑤ ECQM1H122JZ	0.0012
R201	⑤ ERG1ANJ561	560	R302	⑤ ERD25FJ471	470	C202,203	ECEA1HU010	1	C306	ECEA1HU010	1
R202	⑤ ERD25FJ103	10K	R303	⑤ ERD25FJ822	8.2K	C204	⑤ ECQM1H473JZ	0.047	C601 (M)	⑤ ECQF1A473MD	0.047
R203	⑤ ERD25FJ470	47	R304	⑤ ERD25FJ561	560	C205	ECEA0JU221	220	C601 (MC)	⑤ ECQU1A47ME	0.047
R204	⑤ ERD25FJ272	2.7K	R305	⑤ ERD25FJ181	180	C206	ECEA1HU010	1	C601 (Other areas)	⑤ ECNC4A473M	0.047
R205	⑤ ERD25TJ124	120K	R306	⑤ ERD25TJ223	22K	C207	⑤ ECCD1H101K	100P			
R206	⑤ ERD25TJ183	18K	R307	⑤ ERD25FJ272	2.7K	C208	⑤ ECCD1H220K	22P			
R207	⑤ ERD25TJ563	56K	R401	⑤ ERD50FJ152	1.5K	C209	ECEA1CU101	100			
R208	⑤ ERD25TJ224	220K	R601	⑤ ERD50FJ4R7	4.7						
R209	⑤ ERD25TJ334	330K									

REPLACEMENT PARTS LIST

- Notes:**
- Part numbers are indicated on most mechanical parts. Please use this part number for parts orders.
 - Important safety notice:
Components identified by Δ mark have special characteristics important for safety. When replacing any of these components use only manufacturer's specified parts.
 - Bracketed indications in Ref. No. columns specify the area. Parts without these indications can be used for all areas.
 - The "S" mark is service standard parts and may differ from production parts.
 - The parenthesized numbers in the column of description stand for the quantity per set.
 - (K)-marked parts are used only for SL-1210MK2 (black type). And (O)-marked parts are used for SL-1200MK2 (silver type).
 - Parts other than (K)- and (O)-marked are used for both SL-1210MK2 and SL-1200MK2.

Areas

- [M] is available in the U.S.A.
- [MC] is available in Canada.
- [E] is available in Switzerland and Scandinavia.
- [EK] is available in United Kingdom.
- [XL] is available in Australia.
- [EG] is available in F.R. Germany.
- [EB] is available in Belgium.
- [EH] is available in Holland.
- [EF] is available in France.
- [Ei] is available in Italy.
- [XA] is available in Southeast Asia, Oceania, Africa, Middle Near East and Central South America.
- [PA] is available in far East PX.
- [PE] is available in European Military.
- [PC] is available in European Audio Club.

Ref. No.	Part No.	Description	Ref. No.	Part No.	Description	Ref. No.	Part No.	Description
INTEGRATED CIRCUITS			CRYSTAL			LAMP		
IC101	AN6675	Turntable Drive	X201	SVQMS4193	4.193MHz Oscillator	PL1	Δ SFDN122-01	Stylus Illuminator
IC201	AN6680	Turntable Control	VARIABLE RESISTORS			TRANSFORMER		
IC301	AN6682	Pitch Control	VR201	(S) EVTS3MA00B54	Brake Adjustment,50k Ω (B)	T1(M)	Δ SLT66DTL3A	Power Source
IC302	MN4011B	NAND Gate	VR301	EVMH1GA00B23	Pitch Control \pm 0% Adjustment,2k Ω (B)	T1(MC)	Δ SLT66DT14C	Power Source
TRANSISTORS			VR302	(S) EVTS3MA00B54	Pitch Control Gain Adjustment,50k Ω (B)	T1(Other areas)	Δ SLT66DTE13E	Power Source
Q1	2SD1265	Regulator	VR303	SFDZ122N11	Pitch Control	FUSES		
Q2,3	2SD637	Regulator	SWITCHES			F1(MC)	Δ XBA1F12NU14	125V,1.2A
Q201	(S) 2SC1846-R	Regulator	S201,202	EVQP5R04K	Speed Selector	F1 Except for (M,MC)	Δ XBA2C025T1A	250V,T250mA
Q202	2SD637	LED Driver	S401	SFDS02MSL-C	Stylus-Illuminator	F2 Except for (M,MC)	Δ XBA2C10TR0	250V,T1A
Q203	(S) 2SC1328-T	FG Amp.	S601	SFDS55GL13P	Power			
DIODES			S602 Except for (M,MC)	Δ SFDSHXW01317	Voltage Selector			
D1	Δ SVDS1RBA20Z	Rectifier						
D2	MA1051	5.1V Zener						
D201,202	SVDP3902S-9	Speed Indicator						
D203~206	SVDSLH54VT3	Strobe						
D204A	MA162A	Switching						
D301	MA1051	5.1V Zener						
D401	SVDGL-9NG2	Pitch Indicator						

Ref. No	Part No	Description
CHABINET AND CHASSIS PARTS		
1	SFAD122-01A	Dust Cover (1)
2	SFTG172-01	Turntable Mat (1)
3	SFTE172-01	Turntable Platter Ass'y (1)
4	SFUM172-05	Cover, Cabinet (1)
5	SFMGO20-01	Cover, Drive Coil (1)
6	SFMG520-31A	Drive Coil Ass'y (1)
7	SFMZ172-01E	FG Coil Ass'y (1)
8	SFMZQ20-01A	Shaft Ass'y, Turntable (1)
10	○ SFAC122-01	Cabinet (Silver)
10	⊗ SFAC124S01	Cabinet (Black)
11	SFUM172-04	Ornament, Stylus Illuminator (1)
12	SFKT122-01	Knob, Power Switch (1)
13	SFKK122-01E	Case, Strobe Illuminator (1)
14	SFKT015-06	Button, Start/Stop (1)
15	SFOA122-01	Spring, Start/Stop Button (1)
16	SFUM122-01	Base, Operation (1)
17	SFKT015-01E	Button, Speed Ⓚ (1)
18	SFDJ122-02E	Connector, 7pin (1)
19	SFGZ122-01	Spacer, Rubber (1)
20	SFYB-5-32	Ball, Switch Cam (1)
21	SFOA520-01	Spring, Switch Cam (1)
22	SFUM122-03	Cam, Power Switch (1)
23	SFUM015-11	Spacer, Speed Indicator (2)
24	SFKK172-01	Cover, Stylus Illuminator (1)
25	SFXB122-06	Boss, Drive (1)
26	SFOA172-01	Spring, Drive Boss (1)
27	SFXJ172-01	Pin, Lock Canceler (1)
28	SFUP122-02E	Bracket, Stylus Illuminator (1)
29	SFUP122-03	Plate, Lock Operation (1)
30	SFDJ122-03E	Connector, 3pin (1)
31	SFX0172-01	Pin, Guide (1)
32	SFOA520-01	Spring, Lock Canceler (1)
33	SFOA122-02	Spring, Lock Operation Plate (1)
34	SFXJ172-05	Pin, Lock Operation Plate (1)
35 (M,MC,PA PE,PC)	SFHK040L	Clamper, AC Cord (1)
35 (EK)	SFSR-5N-4	Clamper, AC Cord (1)
35 (Other areas)	SFSR-4N-4	Clamper, AC Cord (1)
36 (M,MC,PA PE,PC)	SFUP122-16	Bracket, AC Cord (1)
36 (Other areas)	SFUP122X01	Bracket, AC Cord (1)
37 (M,MC)	RJA9Y	AC Cord (1)
37 (EK) △ ⊕	OFC1205M	AC Cord (1)
37 (XL) △ ⊕	SJAG23	AC Cord (1)
37 △ ⊕	SJAB3	AC Cord (1)
37 (PA,PE,PC)	SJA88	AC Cord (1)
37 (Other areas)		
38	SFGC122-03	Rubber, Power Transformer (2)
39	SFGC122-01	Cushion, Power Transformer (3)
41	SFKT122-02	Knob, Pitch Control (1)
42	○ SFKK122-03	Ornament (Silver), Pitch Control (1)
42	⊗ SFKK124S01	Ornament (Black), Pitch Control (1)
43	SFUZ122-01	Felt (1)
44	SFUP122-09	Holder, LED (1)
45	SFUP122-01	Bracket, Pitch Control (1)
46	SFDJ122-01E	Connector, 4pin (1)
48	SFAU122-02	Bottom Base (1)
48-1	SFAU122-03	Bottom Cover (1)
49	SFUP122-23	Supporter (A), Hinge (2)
50	SFUP122-24	Supporter (B), Hinge (2)
51	SFUMM02N04	Case, Hinge (2)

Ref. No	Part No	Description
52	SFGC122-02E	Insulator (4)
54	SFKT015-02E	Button, Speed 45 (1)
55 (M)	○ SFNN122M10	Name Plate (1)
55 (MC)	○ SFNN122C10	Name Plate (1)
55 (E)	○ SFNN122S10	Name Plate (1)
55 (EK,XL)	○ SFNN122G10	Name Plate (1)
55 (XA)	○ SFNN122X10	Name Plate (1)
55 (PA,PE)	○ SFNN122P10	Name Plate (1)
55 (PC)	○ SFNN122P11	Name Plate (1)
55 (Other areas)	○ SFNN122N10	Name Plate (1)
55 (E)	⊗ SFNN124S10	Name Plate (1)
55	⊗ SFNN124Q10	Name Plate (1)
58	SFATM02N01A	Hinge (2)
59	SFUP122-25	Plate, Power transformer (1)

TO NEARM PARTS		
61	SFPCC31001K	Headshell (1)
62	○ SFPAM18201K	Tonearm Ass'y (Silver) (1)
62	⊗ SFPAM18202K	Tonearm Ass'y (Black) (1)
63	SFPWG17201K	Balance Weight (1)
64	SFPRT18201K	Lift Ass'y (1)
65	SFPZB17202	Knob, Arm Base Lock (1)
66	SFOA829-03	Spring, Lift Ass'y (1)
67	SFPAB13202	Knob, Arm Lift (1)
68	SFPJL18202K	Oil Damper (1)
70	SFPZB12203	Plate, Arm Base Cover (1)
71	SFUM170-06	Spacer, Phono Cord (1)
72	SEPZB12204	Clamper, Phono Cord (1)
73	SFPAB18201K	Tonearm Fixing Plate (1)
74	SFPZB12201K	Plate (1)
75	SFDH122-05	Phono Cord (1)
76	SFEL028-01E	Ground Wire (1)
77	SFPRT17201K	Arm Rest (1)
78	○ SFPKD17203	Arm Base (Silver) (1)
78	⊗ SFPKD17205	Arm Base (Black) (1)
79	SFPKB17204E	Ring, Arm Base Operation (1)
80	SFPKD12201	Bracket, Arm Base (1)
81	SFPAB17206	Knob, Anti-Skating (1)
82	○ SFGK132-01	Cap (Silver) (1)
82	⊗ SFGK133S01	Cap (Black) (1)

SCREW, NUT AND WASHERS		
N1	⊕ XTN3+8BFZ	Screw (5)
N2	SFXGQ20-02	Screw (3)
N3	⊕ XTN3+8B	Screw (8)
N4	⊕ XWG3	Washer (12)
N5	⊕ XTN26+6B	Screw (3)
N6	⊕ XTV3+8BFN	Screw (8)
N7	SFXG172-01	Screw (3)
N8	XTN3+5J	Screw (2)
N9	SFXW172-03	Washer (1)
N10	SFPEW11003	Washer (6)
N11	⊕ XWE3E10	Washer (3)
N12	⊕ XWA3B	Washer (8)
N13	⊕ XSN3+10S	Screw (3)
N14	SFXW910J02	Washer (1)
N15	⊕ XTN3+10B	Screw (5)
N16	⊕ XTN2+10B	Screw (1)
N17	⊕ XUC3FT	Circlip (2)
N18	⊕ XSN17+3FY	Screw (1)
N19	⊕ XUC2FT	Circlip (1)
N20	⊕ XUC25FT	Circlip (1)
N21	⊕ XSN3+14S	Screw (1)
N22	RTW-12	Circlip (1)
N23	⊕ XSN2+10	Screw (2)
N24	⊕ XSN3+6S	Screw (2)
N25	⊕ XTN3+6B	Screw (5)
N26	XTWS3+14TFZ	Screw (6)
N27	SFXG122-02	Screw (1)
N29	SFXG122-01	Screw (4)
N30	XTN3+14OFZ	Screw (6)

Ref. No	Part No	Description
N31	⊕ XWG3FZ	Washer (6)
N32	⊕ XSN3+14BVS	Screw (4)
N33	⊕ XWA3BFZ	Washer (4)
N34	SFXG829-1	Screw (1)
N35	⊕ XSN3+8S	Screw (2)
N36	⊕ XUC5FT	Circlip (1)
N37	SFPEV17202	Screw (3)
N38	⊕ XTN3+25B	Screw (1)
N39	SFPEW1100	Washer (1)
N40	⊕ XSN3+6BVS	Screw (4)
N41	⊕ XWC3BFZ	Washer (1)
N42	⊕ XSN3+12BVS	Screw (2)
N43	⊕ XWG3FZ	Washer (2)
N44	SFXW701-02	Washer (1)
N45	SFPEW00705	Washer (4)
N46	XTW26+5E	Screw (1)

ACCESSORIES		
A1 (M)	SFNU122M06	Instruction Book (1)
A1 (MC)	SFNU122C06	Instruction Book (1)
A1 (E,EB,EC)	SFNU122S01	Instruction Book (1)
A1 (EK)	SFNU122G01	Instruction Book (1)
A1 (PA, PE,PC)	SFNU122P01	Instruction Book (1)
A1 (Other areas)	SFNU122X01	Instruction Book (1)
A2	SFWE010	45 Adaptor (1)
A3	SFPEH3302	Nut, Cartridge (2)
A4	SFPEW9601	Washer, Cartridge (2)
A5	SFCZV8801	Screw, Cartridge (2)
A6	SFPEV9801	Screw, Cartridge (2)
A7	SFK0135-01	Overhang Gauge (1)
A8	SFPZB3501	Shell Weight (1)
A9	△ SFDK119118	2pin Plug (1)
A10	[XA] Only SFPWG17202	Sub-weight (1)
A11	△ QJP0603S	Adaptor, Gimens (1)

PACKING PARTS		
P1 (MC, EF)	○ SFHP122C02	Carton Box (Silver) (1)
P1 (Other areas)	○ SFHP122M02	Carton Box (Silver) (1)
P1	⊗ SFHP124S02	Carton Box (Black) (1)
P2	SFHH122-01	Pad, Front (1)
P3	SFHH122-02	Pad, Rear (1)
P4	SFHD122N05	Pad, Top (1)
P5	SFHD122-02	Pad (A), Turntable (1)
P6	SFHD122N06	Pad (B), Turntable (1)
P7	SFYH60X60	Polyethylene Bag, Unit & Dust Cover (2)
P8	SFYH40X45	Polyethylene Bag, Turntable (1)
P9	SPB1083	Polyethylene Bag, Accessories (3)
P10	SPJ15	Polyethylene Bag, Shell Weight (1)
P11	SFHZD03M01	Cover Sheet, Dust Cover (1)
P12	SFHZ122-01	Cover Sheet, 45Adaptor (1)
P13	SPP189	Cover Sheet, Cords (2)

Note: For the set with serial number sheet change mark \square , the power transformer is fitted as shown below.

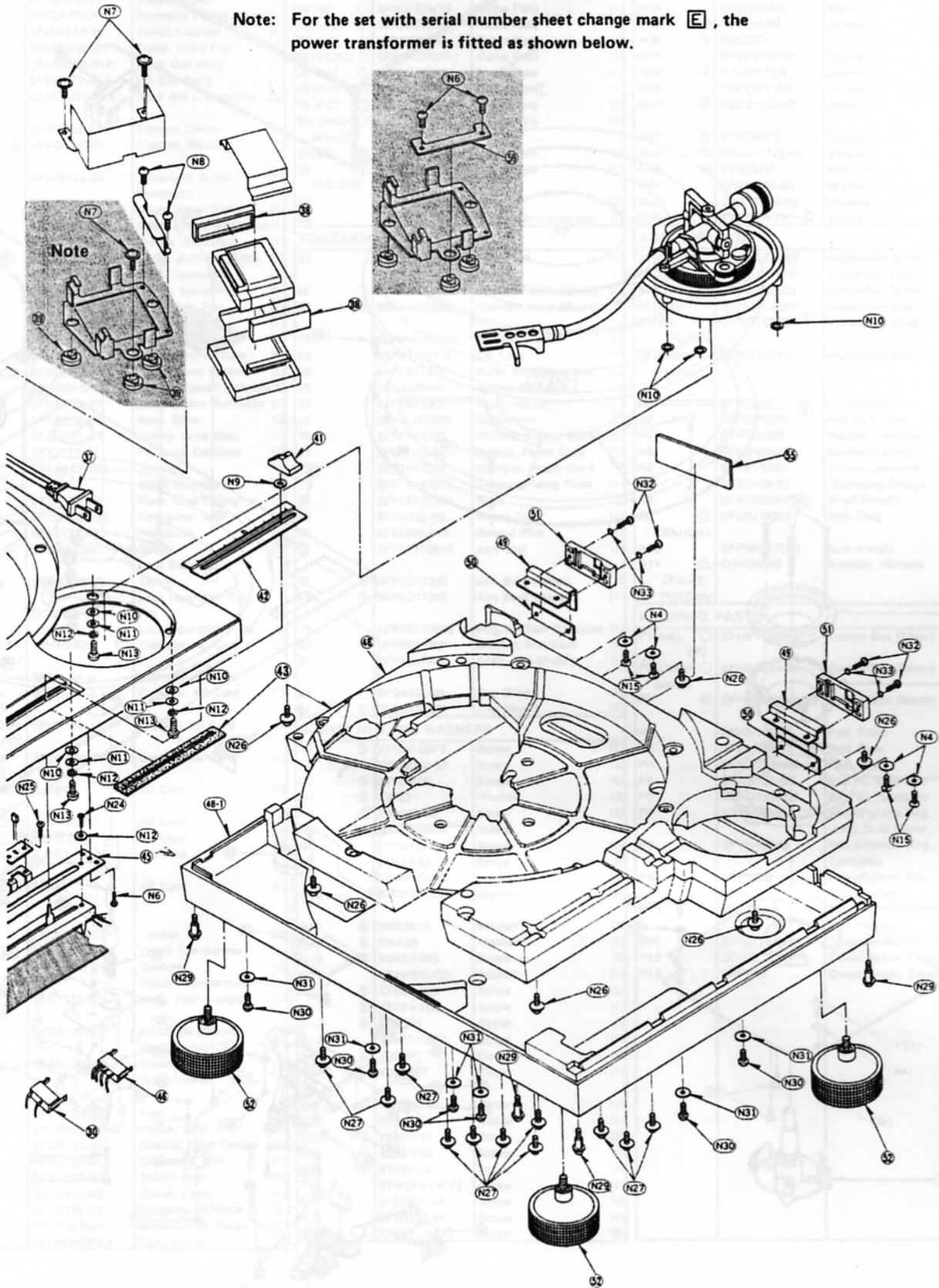

• Tonearm Parts

CIRCUIT BOARD AND WIRING CONNECTION DIAGRAM

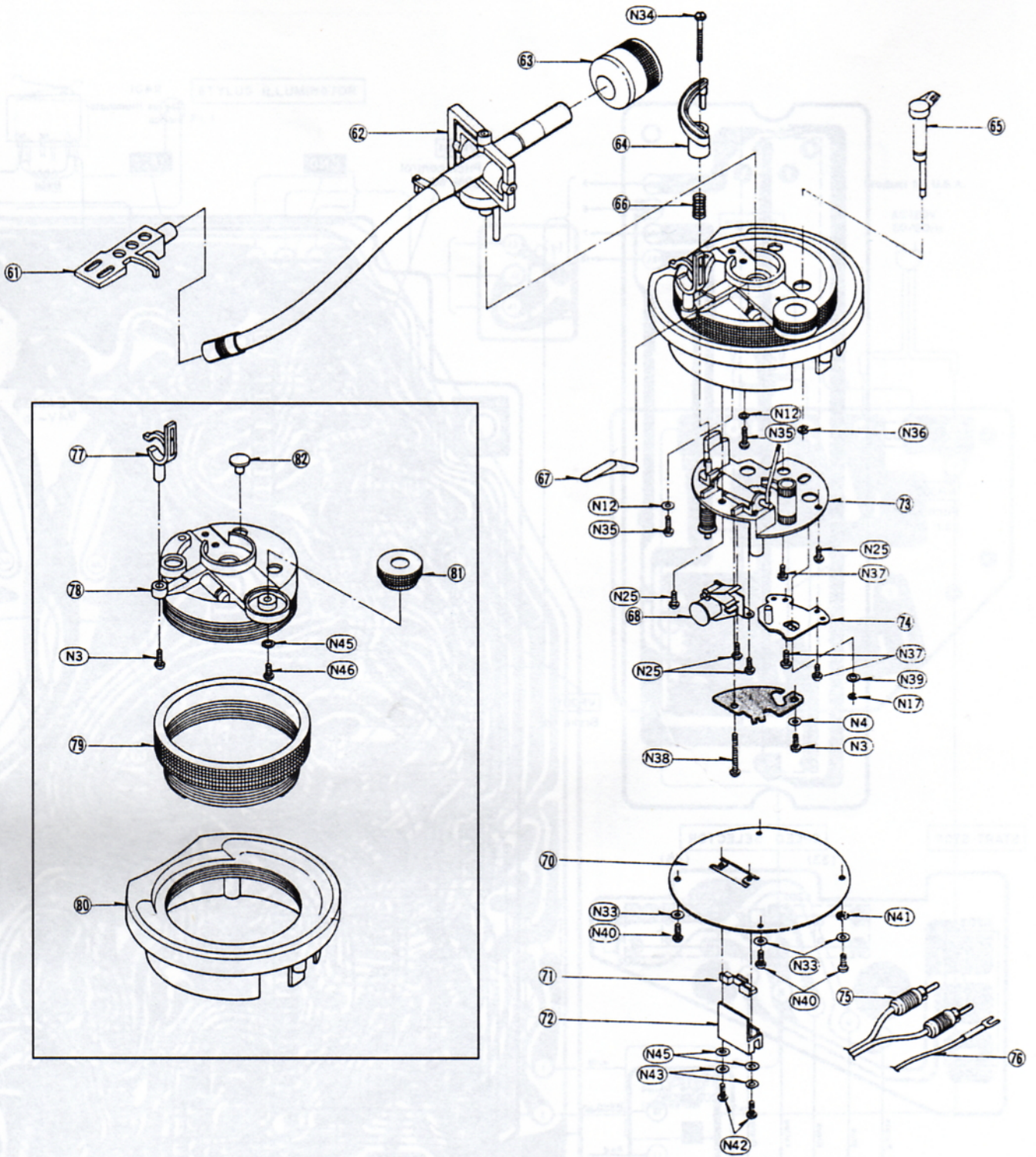

■ CIRCUIT BOARD AND WIRING CONNECTION DIAGRAM

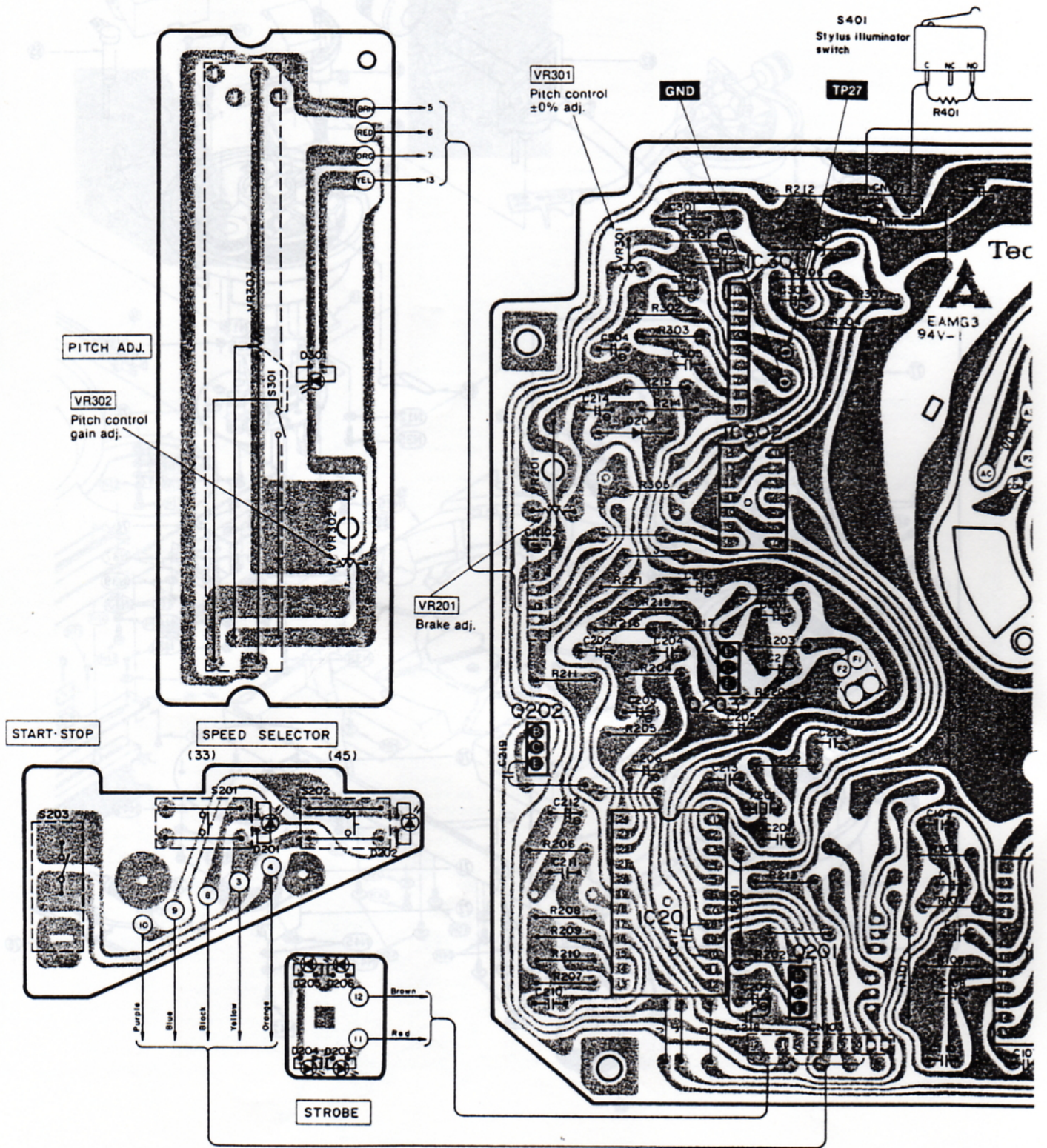

SCHEMATIC DIAGRAM

This schematic diagram may be modified at any time without notice. For information, we will contact you for introduction of the new technology.

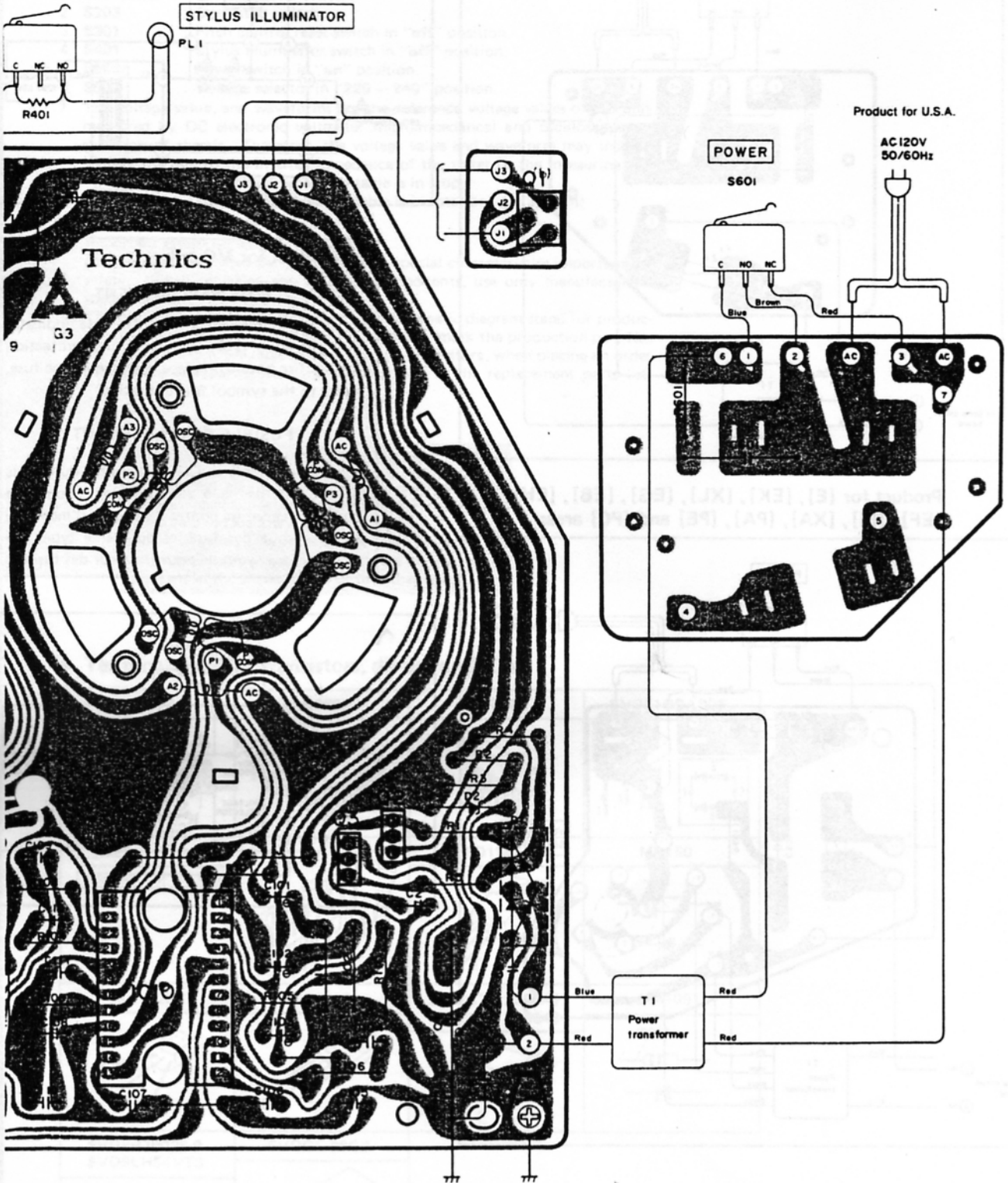

Power source circuit
Product for Canada

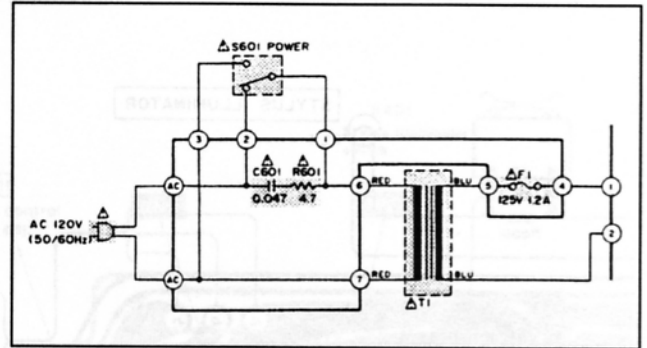
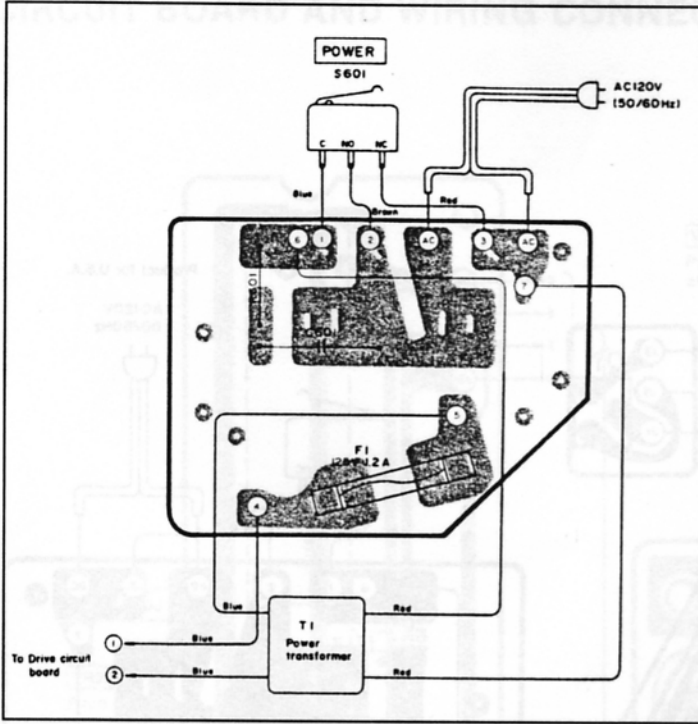

Product for [E], [EK], [XL], [EG], [EB], [EH], [EF], [Ei], [XA], [PA], [PE] and [PC] areas

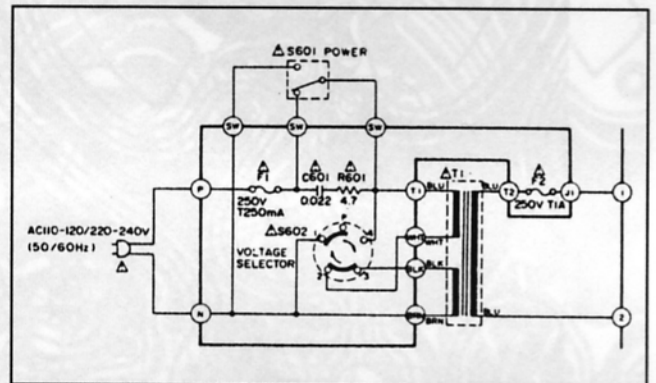
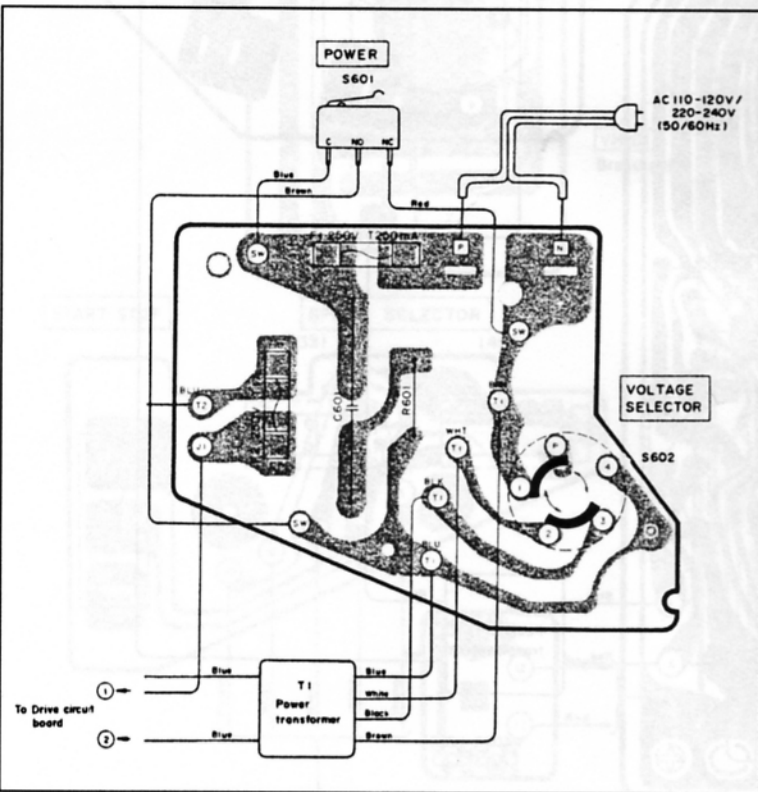

• Product for MC only

FUSE REPLACEMENT

 Symbol located near the fuse indicates fast operating type. For continued protection against fire hazard, replace with same type fuse. Refer to the symbol for fuse rating.





FUSIBLE REMPLACEMENT

 Le symbole qui se trouve près du fusible signifie un fusible à action rapide. Pour une protection continue contre les risques d'incendie, n'utiliser que des fusibles du même type. Se rapporter au symbole pour la valeur des fusibles.

■ SCHEMATIC DIAGRAM

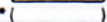
(This schematic diagram may be modified at any time with the development of new technology.)



Notes:

1. **S201, 202** : Speed selector switch.
2. **S203** : Start/stop switch.
3. **S301** : Pitch control reset switch in "off" position.
4. **S401** : Stylus illuminator switch in "off" position.
5. **S601** : Power switch in "on" position.
6. **S602** : Voltage selector in "220 - 240" position.
7. The voltage value, and waveforms are the reference voltage values of this unit measured by DC electronic voltmeter (high-impedance) and oscilloscope on the basis of chassis. Therefore, the voltage value and waveform may include some error due to the internal impedance of the tester or the measuring set.
 - *  is the voltage when turntable is in stop.
 - * () is the voltage when turntable is in rotation. (at 33 rpm)
8.  +B voltage lines.
9. Important safety notice.
Components identified by  mark have special characteristics important for safety. When replacing any of these components, use only manufacturer's specified parts.
10. The part No. of diodes mentioned in the schematic diagram stand for production part No. Regarding the part No. with  mark the production part No. are different from the replacement part No. Therefore, when placing an order for replacement part, please use the part No. in the replacement parts list.

IMPORTANT SAFETY NOTICE

The shaded area on this schematic diagram incorporates special features important for protection from fire and electrical shock hazards. When servicing it is essential that only manufacturer's specified parts be used for the critical components in the shaded areas of the schematic.

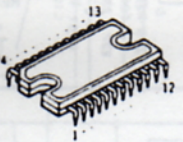
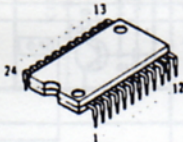
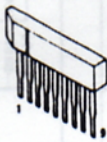
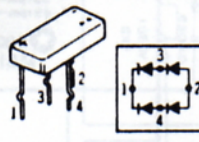
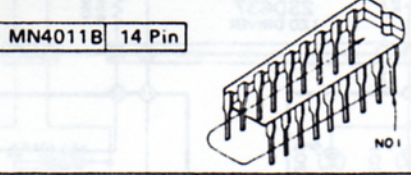
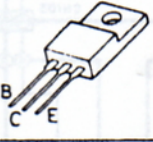
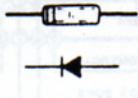
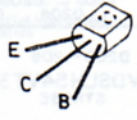
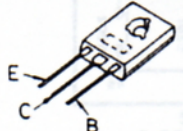
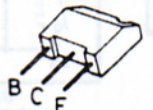
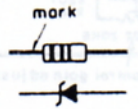
● Terminal guide of transistors, diodes and IC's

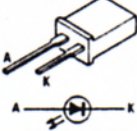
<p>AN6675</p> 	<p>AN6680</p> 	<p>AN6682</p> 	<p>SVDS1RBA20F</p> 
<p>MN4011B 14 Pin</p> 	<p>2SD1265</p> 	<p>MA150</p> 	
<p>2SC1328</p> 	<p>2SC1846</p> 	<p>2SD637 2SB641 2SD636 2SB643</p> 	<p>MA1051</p> 
<p>SVDPR3902S-9 SVDSLH54VT3</p> 	<p>SVDGL-9PG2</p> 		

SL-1200MK2 / 1210MK2

5 6 7 8 9 10

POWER SOURCE CIRCUIT

02,3
2SD637
REGULATOR

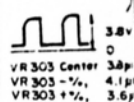
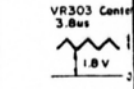
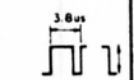
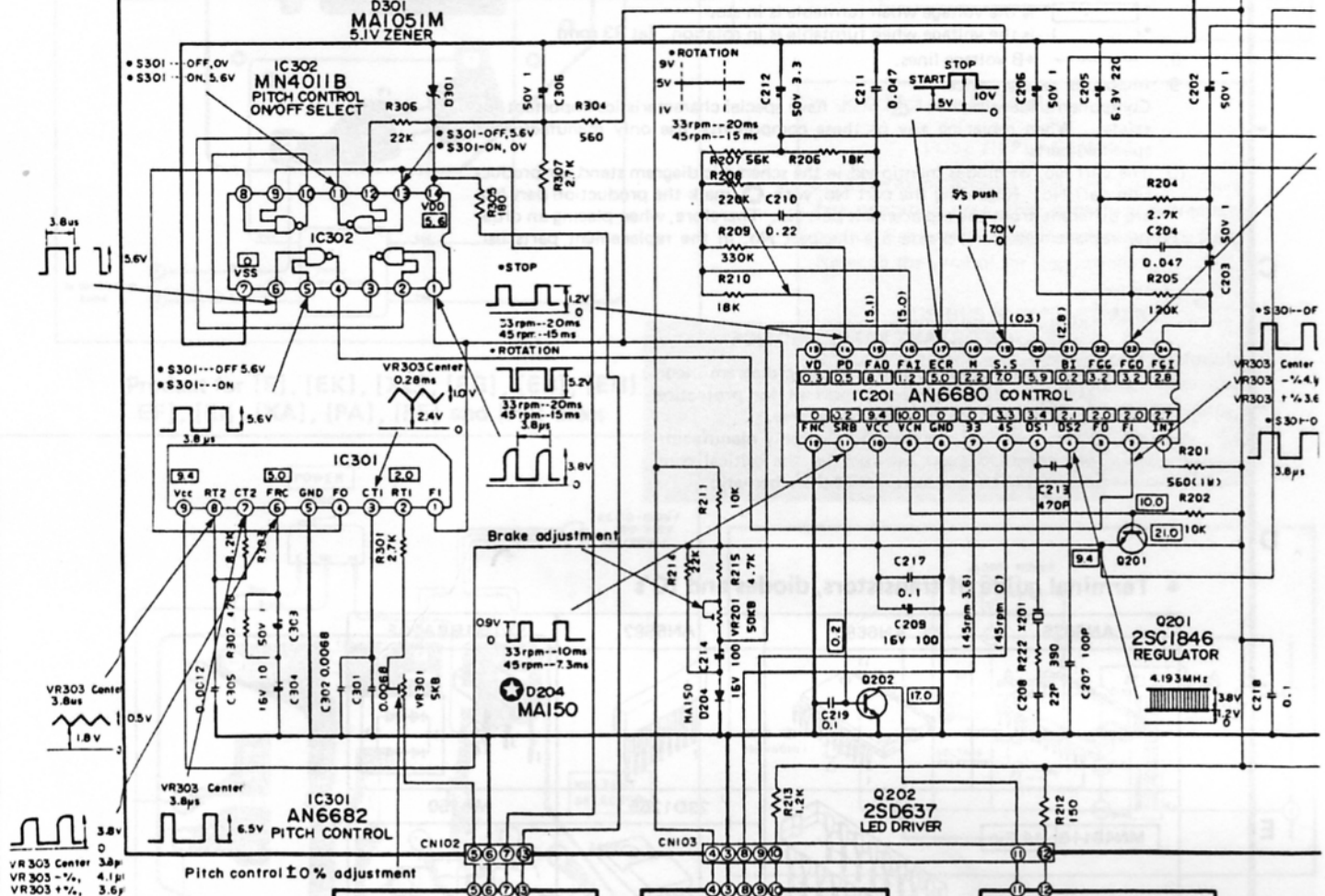
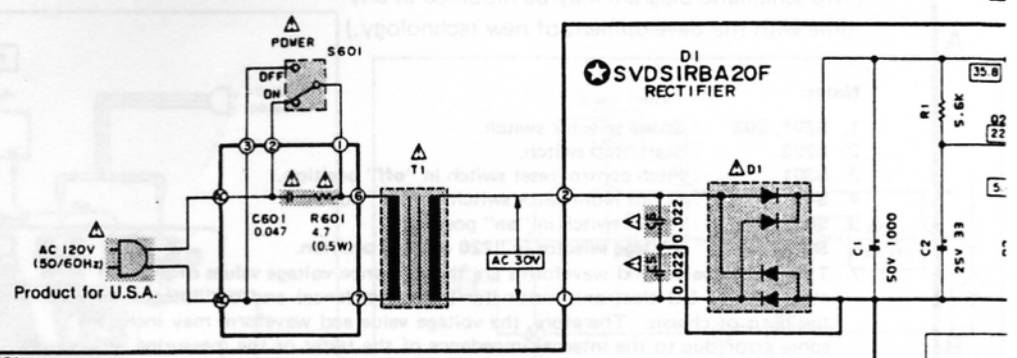

D401
SVDGL-9NG2
PITCH INDICATOR

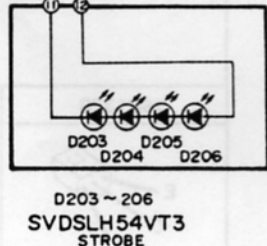
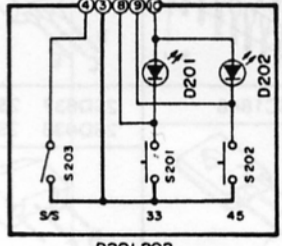
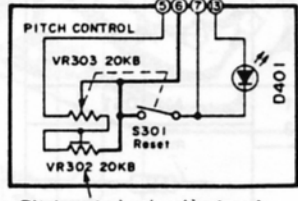

10

11

12

13

14

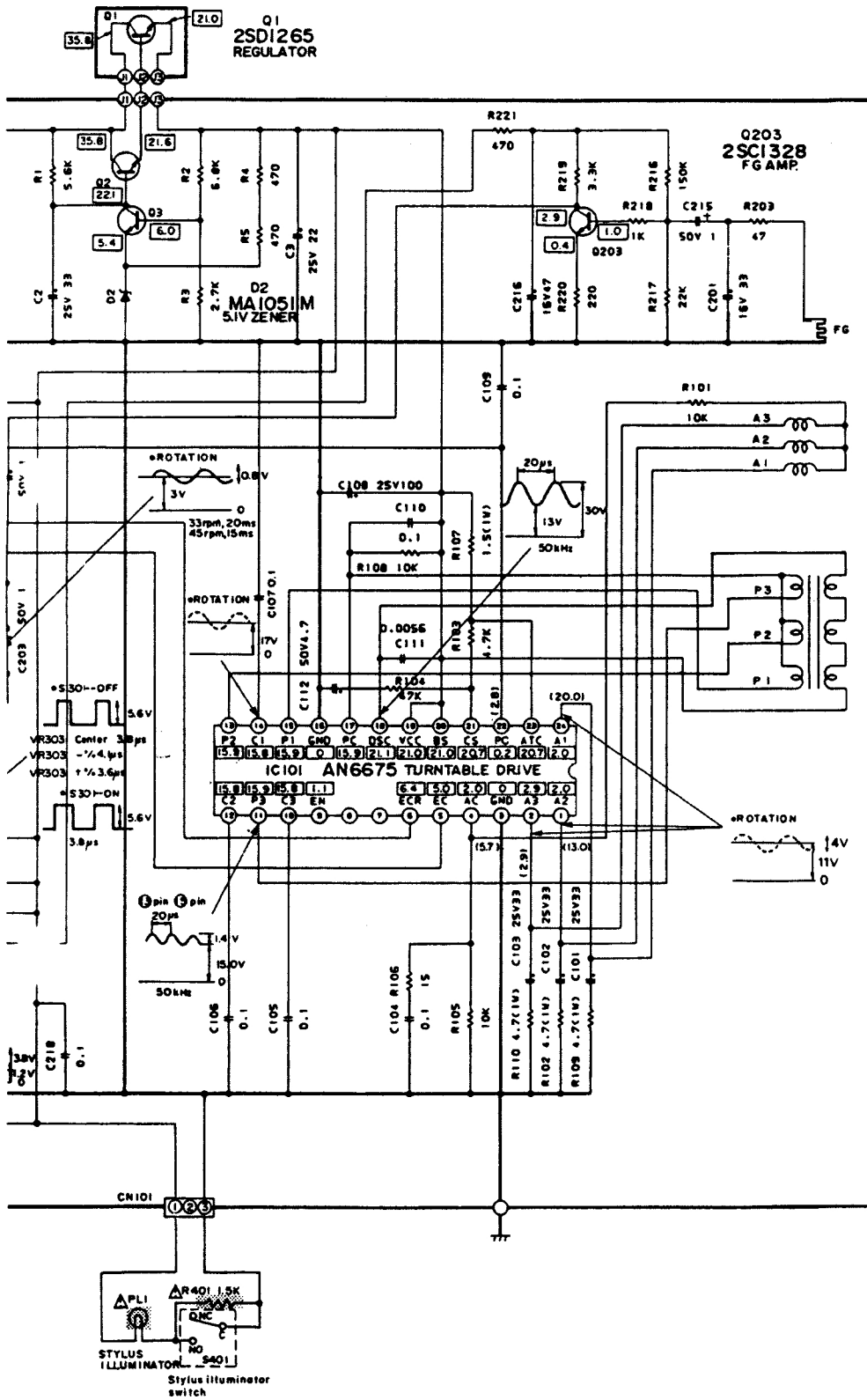

■ BLOCK DIAGRAM

TURNTABLE DRIVE/CONTROL CIRCUIT

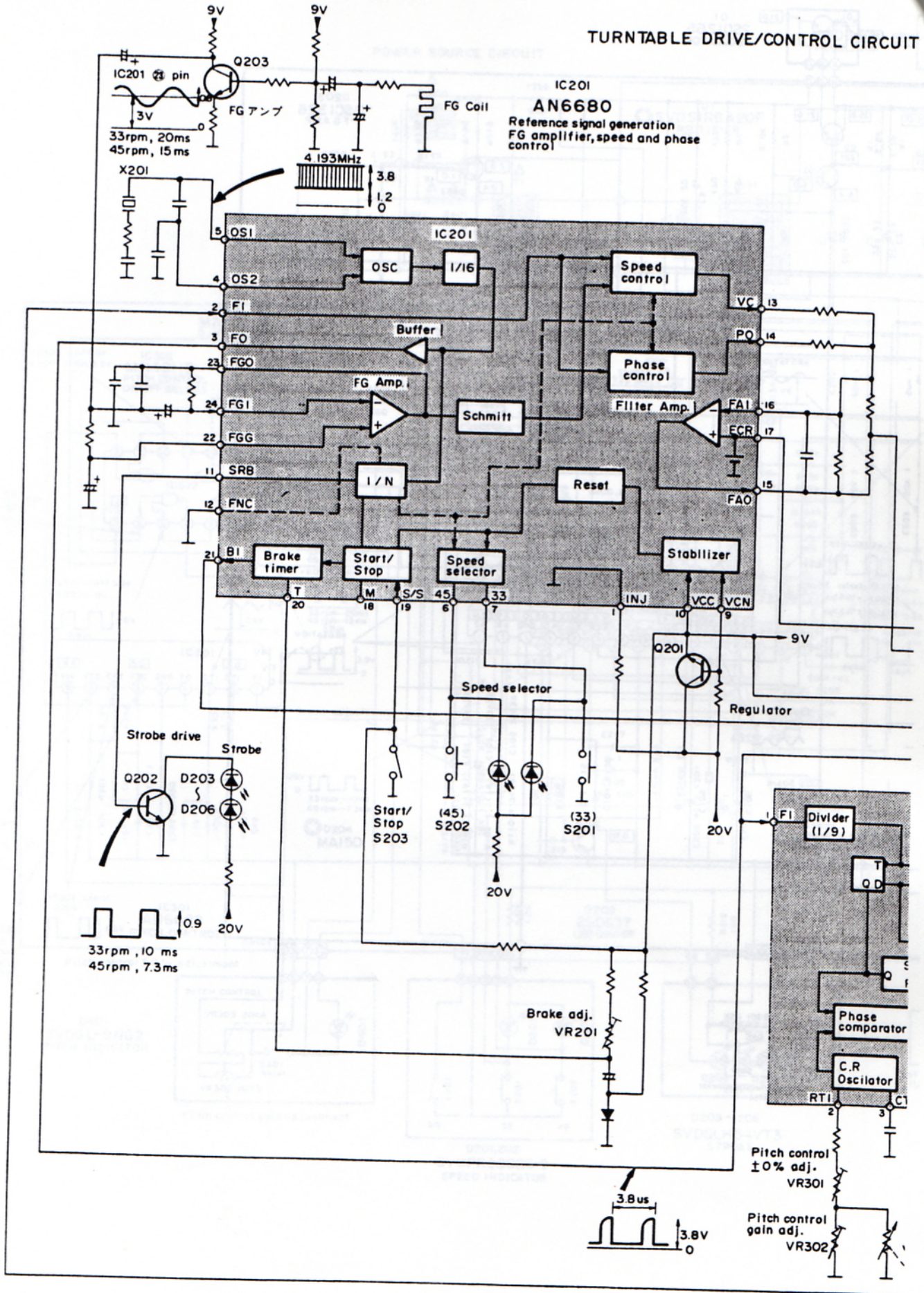

IOL CIRCUIT

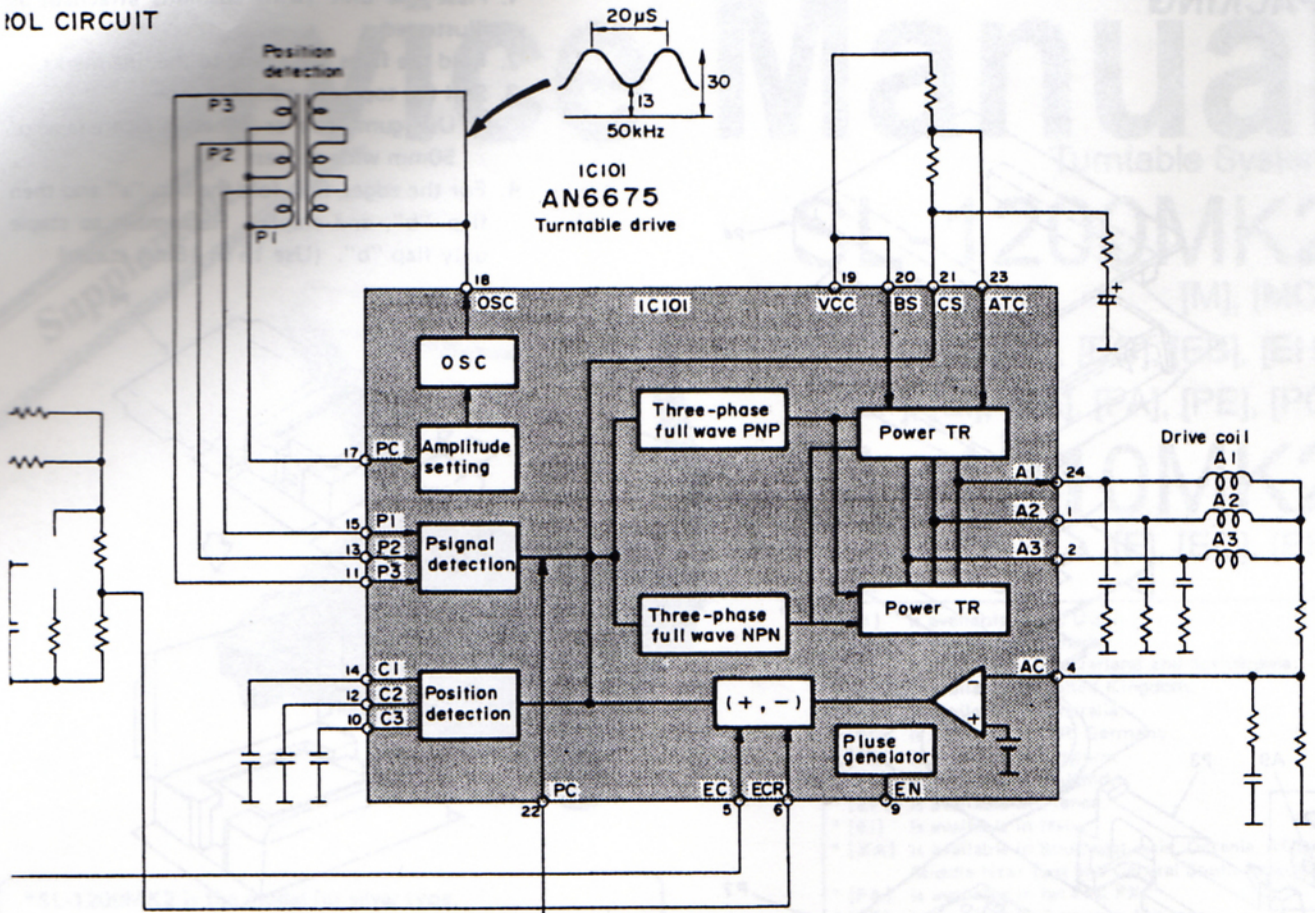

IC301
AN6682
Pitch control

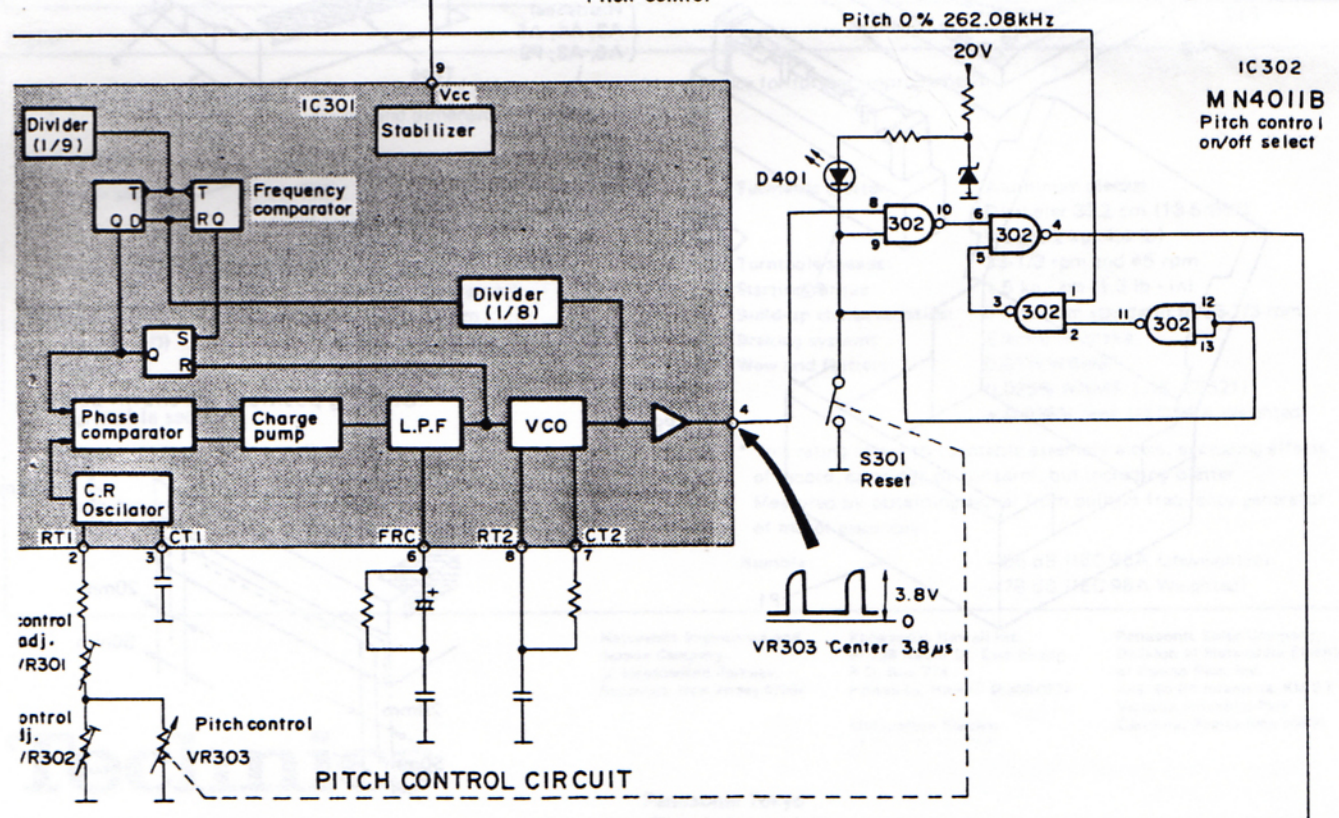

PITCH CONTROL CIRCUIT

PACKING

1. Place the unit (with cushions attached) as illustrated.
2. Fold the flaps according to the line marks.
3. Seal the top with adhesive tape.
 - * Use gum tape or adhesive cloth tape of 50mm wide at least
4. For the edges, first fold the flap "a" and then flap "b", and staple. Remember to staple only flap "b". (Use 15 or 16mm staple)

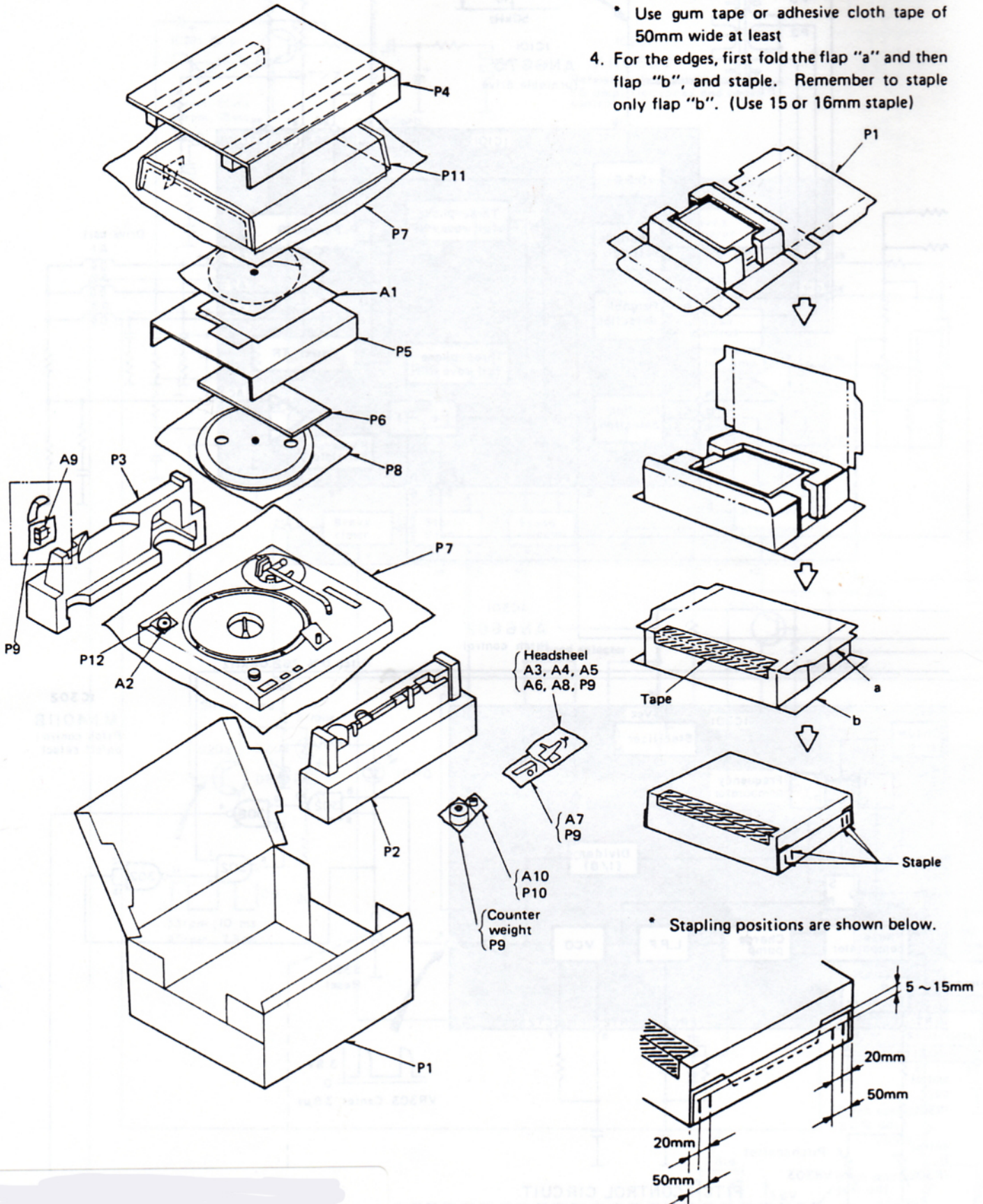

* Stapling positions are shown below.